

# Silhouette™

## Low Sidelobe Antenna for Mobile Operations



### Features

#### Field Proven Performance

#### Advanced Antenna Design

- High gain for maximum range
- Superior directivity to minimize multipath reflections
- Single and multi-band versions

#### Rugged Construction



*The Silhouette™ is ideal for mast mounted applications.*

#### Field Proven Performance

The Silhouette™ is field proven in everyday use with hundreds of antennas in operation worldwide. Its design concept has been imitated; however its performance and quality are unmatched.

#### Advanced Antenna Design

The Silhouette™ incorporates important characteristics that are critical for superior performance - high gain, directivity and selectable polarization - to isolate the microwave link from interference and to provide the maximum area of coverage.

#### Rugged Construction

Ideal for mast-mounted installations, the Silhouette™ is designed to withstand the rigors of remote vehicle operations. The Silhouette™ features a rugged reflector that combines superior strength and light weight. In addition, the Silhouette™ features a rugged single-piece feed support that ensures proper alignment of the feed.



# Silhouette™ Low Sidelobe Antenna for Mobile Operations

## Specifications

Frequency*	Gain**	Azimuth HPBW	Elevation HPBW
2-2.5 GHz	20 dB	14 degrees	22 degrees
7 GHz	30 dB	4 degrees	7 degrees
13 GHz	36 dB	2 degrees	3.5 degrees

\* Other frequencies available upon request.

\*\* Gain referenced to a like-polarized isotrope,, excluding switching options.

## Silhouette™ Dimensions

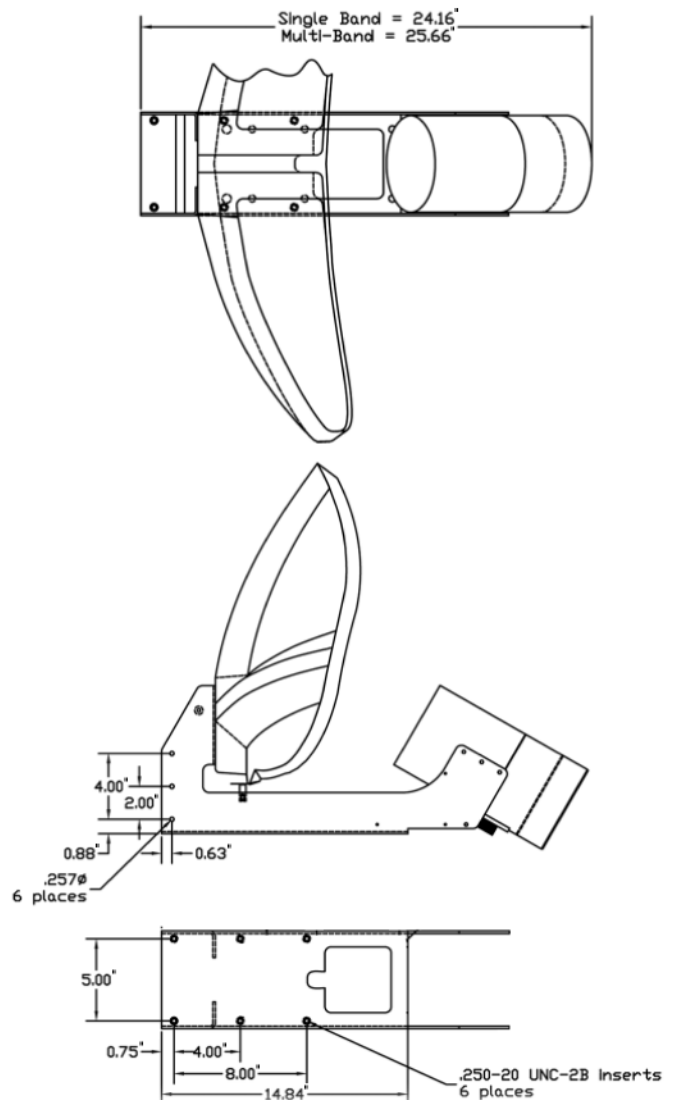
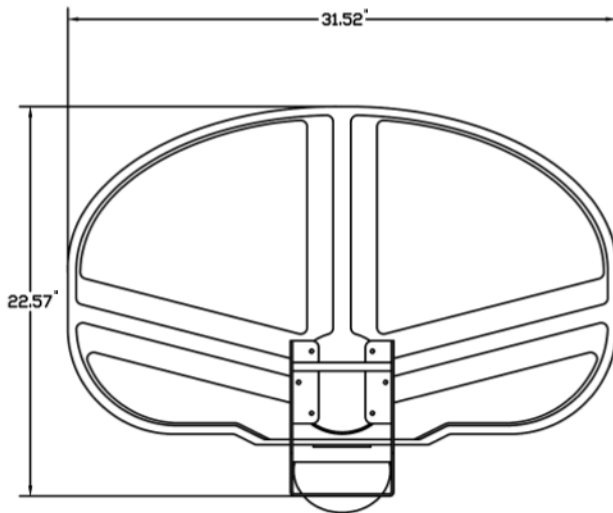

Specifications subject to change without notice.